

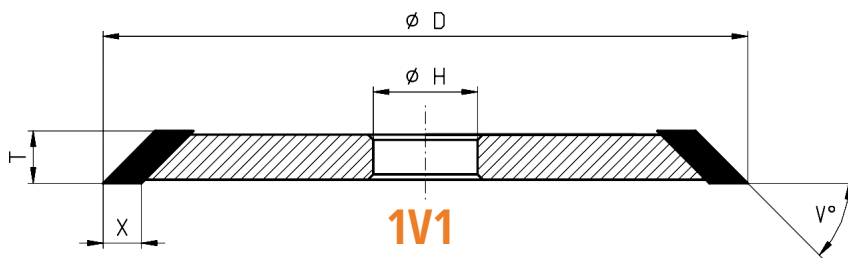

## The wheels you need *when you need them!*



1V1 diamond wheels in stock

Diameter		Bond width (T)	Bond depth (X)	Angle (V)	Grade
mm	inch				
100	4	0.500"	0.375"	80°	D320
100	4	0.500"	0.375"	70°	D320
100	4	0.500"	0.375"	60°	D320
100	4	0.500"	0.375"	45°	D320
125	5	0.500"	0.375"	80°	D320
125	5	0.500"	0.375"	70°	D320
125	5	0.500"	0.375"	60°	D320
125	5	0.500"	0.375"	45°	D320
150	6	0.500"	0.375"	80°	D320
150	6	0.500"	0.375"	70°	D320
150	6	0.500"	0.375"	60°	D320
150	6	0.500"	0.375"	45°	D320

No wait. No worries. You will *LOVE* these wheels!

- **High stock removal rates at high feed rates.** Our Toolgal iQ diamond wheels are comparable to Norton G-Force and other world-class grinding wheels.
- **Excellent edge quality and durability,** so you can maintain tight tolerances
- **Outstanding surface finishes**
- **Predictable performance,** so you can repeat the feeds and speeds you liked with previous Toolgal wheels without worry
- **Great bang for the buck.** Great prices. Dollar for dollar, they'll perform better than any other wheels.



**Call:** +1 (540) 940-5977  
**Email:** info@toolroom.solutions  
**Web:** www.toolroom.solutions





**Same-Day Shipping**  
if you order by 3 PM ET!

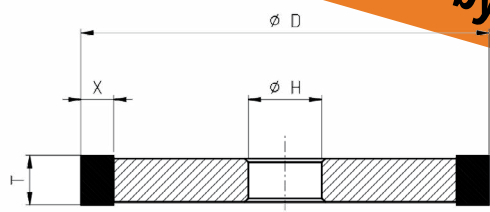

**1A1**

1A1 diamond wheels in stock				
Diameter		Bond width (T)	Bond depth (X)	Grade
mm	inch			
100	4	0.500"	0.375"	D240
100	4	0.500"	0.375"	D320
125	5	0.500"	0.375"	D240
125	5	0.500"	0.375"	D320
150	6	0.500"	0.375"	D240
150	6	0.500"	0.375"	D320

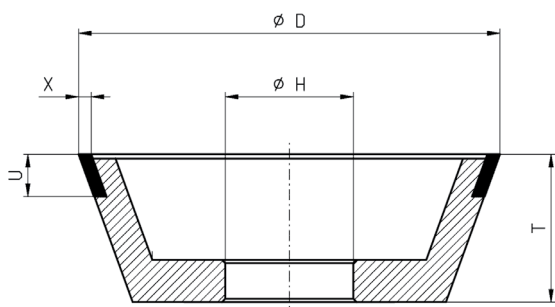

**11V9**

11V9 diamond wheels in stock					
Diameter		Wheel depth	Bond width (U)	Bond depth (X)	Grade
mm	inch				
100	4	35 mm	0.375"	0.125"	D240
100	4	35 mm	0.375"	0.125"	D320
100	4	35 mm	0.375"	0.125"	D400

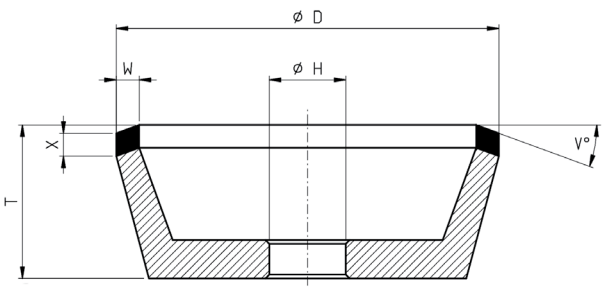

**11V5**

11V5 diamond wheels in stock						
Diameter		Wheel depth	Bond width (U)	Bond depth (X)	Angle (V)	Grade
mm	inch					
100	4	40 mm	0.25"	0.25"	30°	D320

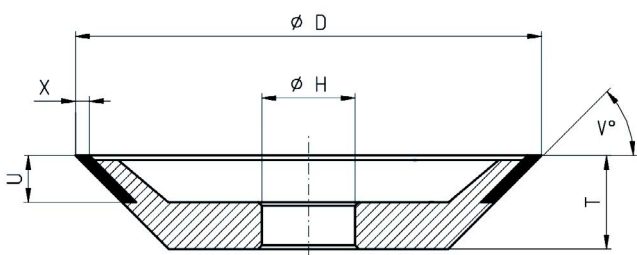

**12V9**

12V9 diamond wheels in stock						
Diameter		Wheel depth	Bond width (U)	Bond depth (X)	Angle (V)	Grade
mm	inch					
125	5	20 mm	0.375"	0.125"	45°	D320
125	5	20 mm	0.375"	0.125"	30°	D320

Don't see what you need? We may still have it and if it's not in stock delivery can be as fast as two weeks. Give us a call!



**Call:** +1 (540) 940-5977  
**Email:** info@toolroom.solutions  
**Web:** www.toolroom.solutions

