

# Grinding wheel adapters

and  
Accessories



good better BLUE

20 YEARS  
since 1998 GDS



## Grinding wheel adapter and accessories

Precision grinding requires an optimal spindle and a flawless grinding wheel, both of which depend on a perfect grinding wheel adapter.

# "Our quality for your success"

We adapt to your requirements and guarantee our quality.

**GDS - the precision makers**



Our grinding wheel adapters are characterised by the following:



Maximum taper accuracy by using constantly controlled and calibrated measuring equipment.



Absolute accuracy of fit and optimum radial and axial run-out.



Extreme load-bearing capacity due to the use of tempered material and the best heat treating processes.



Optimum surface quality and associated long-term dimensional stability and precision, as well as spindle protection as a result of finished surfaces.



Balanced models for improved grinding results and spindle life.

# Vollmer HSK-C50 // Shaft $\varnothing 31.75$ mm // RS $\varnothing 60$ mm

For Vollmer VGRIND tool grinding machines with ring set  $\varnothing 60$  mm

## GWA HSK50 // $\varnothing 31.75$ mm // RS $\varnothing 60$ mm

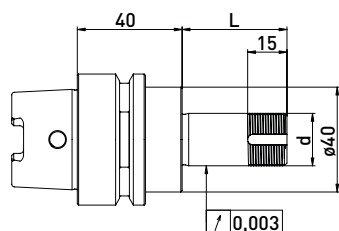
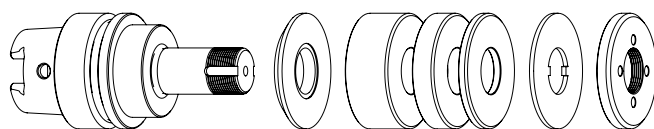

Delivered equipped:  
Reducing washer, ring set  $\varnothing 60$  mm, lock washer and clamping nut

### Ring set $\varnothing 60$ mm

Order No.	HSK	d	L	B 20	B 10	B 4
300012112	HSK50	20	40	-	1	3
300012122	HSK50	20	60	1	1	3
300012132	HSK50	20	75	1	2	4
300012142	HSK50	20	85	2	1	4
300012152	HSK50	20	100	2	3	3

## Accessories Vollmer grinding wheel adapter HSK50 // $\varnothing 31.75$ mm // Ring set $\varnothing 60$ mm

Order No.	Name	
350050010	Universal assembly device $\varnothing 50$	
350040030	*Clamping nut wrench PC39 for clamping nut with blancing option	
350040020	Clamping nut wrench PC45 for $\varnothing 32$	
350020023	*Balancing weight pair for clamping nut $\varnothing 60$ // 200gmm	

Order No.	Name	
350011420	Spacer ring $\varnothing 60$ x $\varnothing 31,75$ x 20	
350011410	Spacer ring $\varnothing 60$ x $\varnothing 31,75$ x 10	
350011404	Spacer ring $\varnothing 60$ x $\varnothing 31,75$ x 4	
350030060	Lock washer $\varnothing 60$ x $\varnothing 32$ x 1,8	
350020066	Clamping nut $\varnothing 60$ x 6 x M32 x 1,5 PC45	
350020022	*Clamping nut with balancing option $\varnothing 60$ x 9 M32 x 1,5 PC39	

\*related items

# Vollmer HSK50 // Schaft $\varnothing 20$ mm // RS $\varnothing 35$ mm

For Vollmer VGRIND tool grinding machines with ring set  $\varnothing 35$  mm

## GWA HSK50 // $\varnothing 20$ mm // RS $\varnothing 35$ mm

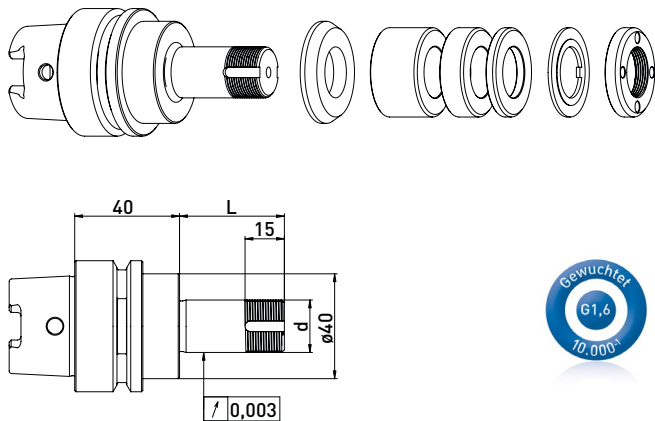

Delivered equipped:  
Reducing washer, ring set  $\varnothing 35$  mm, lock washer and clamping nut

Ring set  $\varnothing 35$  mm

Order No.	HSK	d	L	B 20	B 10	B 4
300012512	HSK50	20	40	-	1	3
300012522	HSK50	20	60	1	1	3
300012532	HSK50	20	75	1	2	4
300012542	HSK50	20	85	2	1	4
300012552	HSK50	20	100	2	3	3

## GWA HSK50 // $\varnothing 20$ mm // without RS

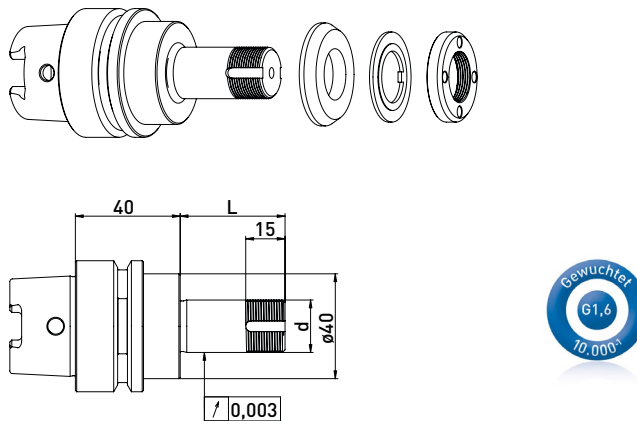

Delivered equipped:  
Reducing washer, lock washer and clamping nut

Order No.	HSK	d	L
300012511	HSK50	20	40
300012521	HSK50	20	60
300012531	HSK50	20	75
300012541	HSK50	20	85
300012551	HSK50	20	100

## Accessories Vollmer grinding wheel adapter HSK50 // $\varnothing 20$ mm // Ring set $\varnothing 35$ mm

Order No.	Name	
350050010	Universal assembly device $\varnothing 50$	
350040010	Clamping nut wrench PC27 for $\varnothing 20$	
350040011	Clamping nut wrench PC27 for $\varnothing 20$	
350040040	*Clamping nut wrench PC29 for $\varnothing 20$ for clamping nut with blancing option	
350040041	*Spannmutterschlüssel TK29 für $\varnothing 20$	
350020081	*Balancing weight pair for clamping nut $\varnothing 35$ // 40gmm	

Order No.	Name	
350012020	Spacer ring $\varnothing 35$ x $\varnothing 20$ x 20	
350012010	Spacer ring $\varnothing 35$ x $\varnothing 20$ x 10	
350012004	Spacer ring $\varnothing 35$ x $\varnothing 20$ x 4	
350015006	Reducing washer $\varnothing 40$ x $\varnothing 35$ x $\varnothing 20$ x 6	
350030020	Lock washer $\varnothing 35$ x $\varnothing 20$ x 2	
350020030	Clamping nut $\varnothing 35$ x 6 M20 x 1 PC27	
350020080	*Clamping nut with balancing option $\varnothing 35$ x $\varnothing 40$ x 8 x M20 x 1 PC29	
350015005	Support washer $\varnothing 35$ x $\varnothing 60$ x $\varnothing 20$ x 6	

\*related items

# Vollmer HSK50 // Shaft $\varnothing 20$ mm // RS $\varnothing 50$ mm

For Vollmer VGRIND tool grinding machines with ring set  $\varnothing 50$  mm

## GWA HSK50 // $\varnothing 20$ mm // RS $\varnothing 50$ mm

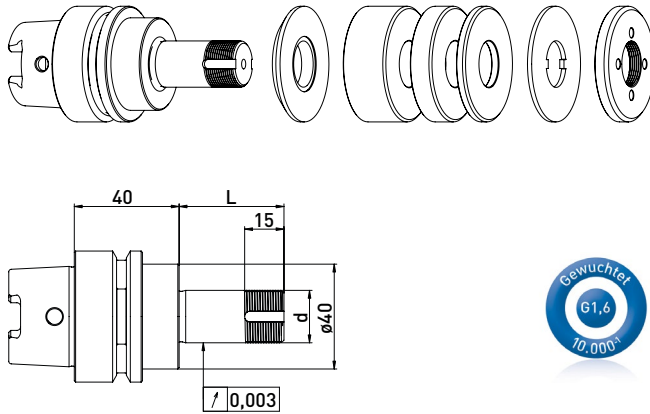

Delivered equipped:  
Reducing washer, ring set  $\varnothing 50$  mm, lock washer and clamping nut

Ring set  $\varnothing 50$ mm

Order No.	HSK	d	L	B 20	B 10	B 4
300012012	HSK50	20	40	-	1	3
300012022	HSK50	20	60	1	1	3
300012032	HSK50	20	75	1	2	4
300012042	HSK50	20	85	2	1	4
300012052	HSK50	20	100	2	3	3

## GWA HSK50 // $\varnothing 20$ mm // without RS

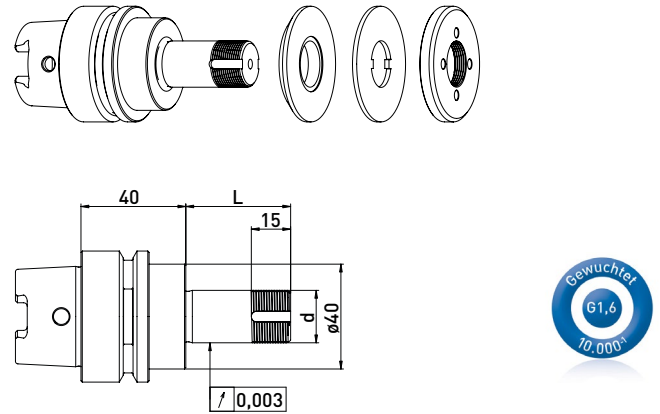

Delivered equipped:  
Reducing washer, lock washer and clamping nut

Order No.	HSK	d	L
300012011	HSK50	20	40
300012021	HSK50	20	60
300012031	HSK50	20	75
300012041	HSK50	20	85
300012051	HSK50	20	100

## Accessories Vollmer grinding wheel adapter HSK50 // $\varnothing 20$ mm // Ring set $\varnothing 50$ mm

Order No.	Name	
350050010	Universal assembly device $\varnothing 50$	
350040010	Clamping nut wrench PC27 for $\varnothing 20$	
350040011	Clamping nut wrench PC27 for $\varnothing 20$	
350020021	*Balancing weight pair for clamping nut $\varnothing 50$ // 100gmm	

Order No.	Name	
350011020	Spacer ring $\varnothing 50$ x $\varnothing 20$ x 20	
350011010	Spacer ring $\varnothing 50$ x $\varnothing 20$ x 10	
350011004	Spacer ring $\varnothing 50$ x $\varnothing 20$ x 4	
350015002	Reducing washer $\varnothing 40$ x $\varnothing 50$ x $\varnothing 20$ x 6	
350030010	Lock washer $\varnothing 50$ x $\varnothing 20$ x 2	
350020060	Clamping nut $\varnothing 50$ x 6 x M20 x 1 PC27	
350020020	*Clamping nut with balancing option $\varnothing 50$ x 8,5 M20 x 1,0 PC27	
350015003	Support washer $\varnothing 50$ x $\varnothing 75$ x $\varnothing 20$ x 6	



μGrind HPS 20 // HPS 20L



μGrind Nann 3409E



μGrind HSK



μGrind Hydro



Our Clamping and balancing technology catalogue contains all our quick-acting chucks.

In North America contact:

**Toolroom Solutions Inc.**

8824 Old Block House Ln  
Spotsylvania, VA 22551 USA

Tel: +1 (540) 940-5977  
Email: [info@toolroom.solutions](mailto:info@toolroom.solutions)  
Web: [www.toolroom.solutions](http://www.toolroom.solutions)



GDS Präzisionszerspanungs GmbH  
Endelbergstrasse 8  
D - 72131 Offerdingen

